



GRANDPERSPECTIVE

White paper



Real Time Gas Cloud Mapping for the Chemical Industry



Introduction

Gas leaks of toxic or flammable gases are a huge and yet often underestimated hazard potential in the chemical industry. More than 30%* of dangerous gas leaks are not detected by gas sensors. Once airborne, tracking the exact location, distribution and direction of a gas cloud is all but impossible using traditional methods.

69% of significant gas releases are undetected by gas sensors*

36% of major gas releases are undetected by gas sensors*

* Source: Health and Safety Executive (HSE) Offshore Hydrocarbons Release database

The Challenge of Conventional Gas Leak Detection

All conventional gas warning systems have one common shared foundation. That is, the gas cloud, they are designed to detect, must physically touch the sensor before it can be identified. However, depending on the circumstances, gas clouds can change their location very quickly and unpredictably. This random and often unforeseeable distribution makes it impossible to place a fixed gas sensor in the correct spot. And even hand-held mobile gas sensors have their limitations: Without knowing the location of a gas cloud, detecting a leak is like trying to find an object in the dark. This is because all conventional gas sensors work like a human nose. Wouldn't it be more convenient to have a system that works like the human eye? This is where infrared spectroscopy gas monitoring can make a profound and palpable difference to visibility by providing real-time detection and area monitoring.



Example illustration of how a gas cloud moves.



Scope of an Early Warning Solution

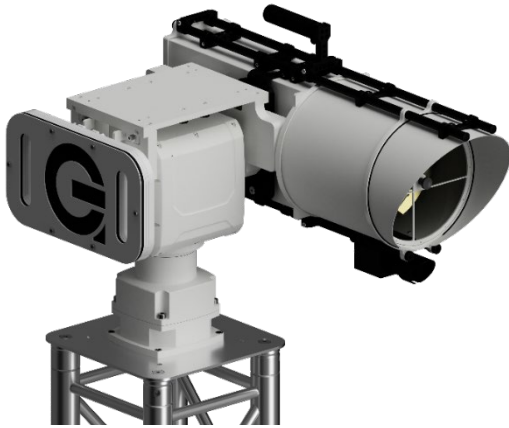

Grandperspective GmbH is an emission monitoring company, which specializes in hyperspectral imaging based on Fourier-Transform infrared (FTIR) remote sensing technology. Its remote monitoring technique offers both an early warning system for dangerous instantaneous emissions and a continuous leak detection system, enabling plants to detect the smallest leakages over extended measurement times. Identifying and monitoring large spontaneous emissions, which can occur at various points in the process, also presents a significant challenge for

operators. Rapid detection is crucial and the only way to stay ahead of the curve is for control rooms to have real-time visibility of a leak before it becomes a potential incident.

For this to happen, the gas cloud must be fully assessed and information relating to the location, size and concentration distribution within the cloud must be sent immediately to the Distributed Control System (DCS). Once the gas cloud has been located, the moving gas cloud must be tracked in order to define hazard zones for risk mitigation. Information on the position and distribution of the gas cloud is essential for a rapid response by first responders. Finally, when the event is over, the system information for de-escalation needs to be communicated to all relevant parties.

Situation Assessment from the Distance

What does efficient and effective remote monitoring look like? Industry-leading remote monitoring is the ability to assess a situation in real-time from large distances.

Grandperspective's remote scanfeld® sensors are able to continuously and autonomously identify, monitor and quantify hundreds of gases at detection rates of 0.05 kg/hr or less - across a radius of one square kilometer.

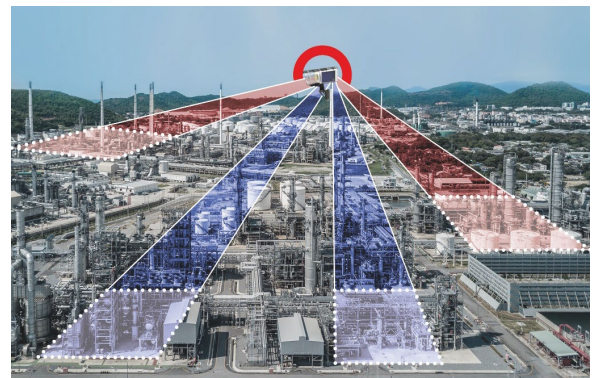

The scanfeld® early warning solution uses remote monitoring sensor units to detect a gas release in real time, assesses and visualizes the gas cloud distribution and tracks the moving gas cloud. The technology allows operators to detect a gas release without any previous knowledge of its location. Moreover, for the first time, it also enables safety teams to assess the entire gas cloud, rather than simply measuring arbitrary concentration values at uncertain positions.



Hyperspectral scanfeld® Sensor Units: How FTIR Spectroscopy Works

The hyperspectral sensor units are remote sensing gas analyzers for the identification of hazardous gas over long distances (up to 1 km). The measurement principle is based on passive Fourier-transform infrared (FTIR) spectroscopy. Passive means it makes use of natural infrared radiation (thermal heat radiation), so no sunlight or artificial light is required, the system works day and night.

The FTIR spectrometer analyses the infrared radiation spectrally over a wide spectral range at a high spectral resolution, i.e., with hundreds of spectral channels, making the scanfeld® sensor units true hyperspectral systems. Each gas that is in the field of view of the instrument leaves a compound-specific spectroscopic fingerprint in the measured spectrum. With this technology over 400 hundred different chemicals can be identified, and even mixtures of different gases can be analyzed for their composition.

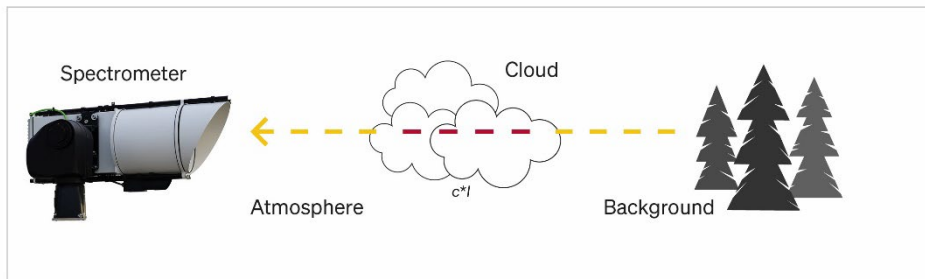

The scanfeld® sensor units are radiometrically calibrated automatically and need no compound-specific calibration for the analysis of the target gases, moreover the method of FTIR spectroscopy provides a very high dynamic range, i.e., it works over an exceedingly large concentration range from single digits ppm to double digits % range. This allows the system to stay operable even in the event of a massive spill of a hazardous compound. In the spectral region used by the sensor units the system is fairly insensitive to fog or dust particles, due to the long wavelength of the used infrared radiation. The sensor units are scanning-imaging hyperspectral devices. Positioning and scanning are done by highly precise military-grade 360° pan-and-tilt units. By scanning a defined area, they analyze the gas composition in any viewing direction thus assessing the gas cloud distribution.

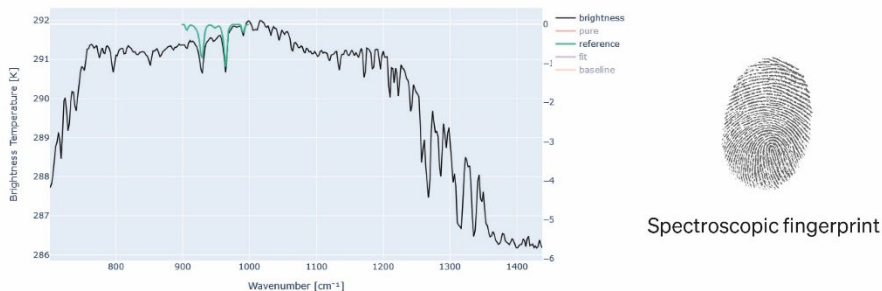

Within one scan, many individual measurements are taken. A brightness temperature spectrum in Kelvin (black line) is recorded at each measuring point (toxel). This spectrum is compared with a high-resolution gas spectrum from a reference library (green line). This "correlation" is used to assess whether a gas has been detected or not.



The Advantages of FTIR Spectroscopy

- Autonomous continuous monitoring
- Real-time gas cloud mapping
- High coverage with just a few sensor units
- Long distance measurements
- Passive measurement working day and night
- Robust operation even in challenging climate conditions
- Can measure multiple gases at the same time.

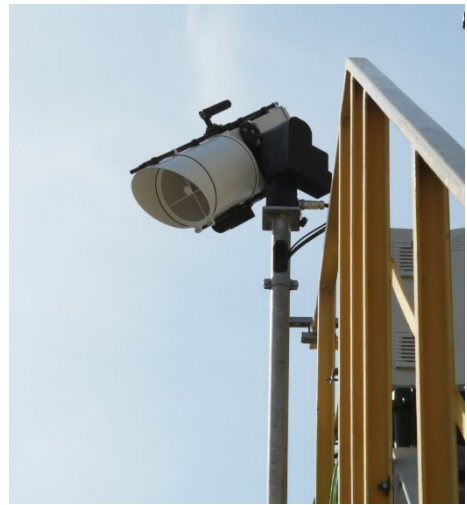

Case Study: Chemelot Industrial Park

The Chemelot industrial Park in the Netherlands is one of the largest chemical parks in Europe. It is home to numerous petrochemical companies - including but not limited to – OCI N.V., Arlanxeo Netherlands B.V., Fibrant B.V., AnQore B.V. and SABIC. The two major production streams onsite convert naphtha/gasoil to hydrocarbons or plastics and natural gas to ammonia, fertilizers and performance chemicals.





The primary aim of Grandperspective's remote sensing technology is two-fold. Firstly, the technology provides early warning of hazardous ammonia releases, and secondly, it delivers specific situation assessment for the entire park within minutes. Number and positioning of the sensor units is determined by the scope of the monitoring plan. Each individual sensor unit can cover a radius of up to 1 km.

Since 2021, two scanfeld® sensor units have been continuously monitoring four stacks and a urea plant at the OCI melamine production facility. The two sensor units also oversee the Brightlands campus area, where they provide 24/7, 365 days area monitoring coverage to an area spanning approximately 350,000 m². In 2024, a further four sensors will be deployed to cover the entire Chemelot north site, extending visibility and reach to 1.6 km².

For safety staff at Chemelot, the three greatest benefits of the remote monitoring system are:

- Swift detection at levels from 10 ppm,
- Visualization of the gas cloud in the control room in real time, and;
- Near-zero false alarms.

However, safety managers also cite the following attributes as hugely beneficial to providing industry-leading area monitoring coverage:

- Continuous operation for at least 99.9 % of the time
- On-site data storage
- Full on-premises installation without dependence on cloud solutions in critical situations
- 24/7 expert support in case of outages.



Gui Hoedemakers, AnQore B.V.'s Head of Safety, Health and the Environment (SHE) is an advocate of Grandperspective's remote monitoring system – he thinks it could be a potential turning point for sensor technology. “The new system has enabled AnQore to “detect, identify, and quantify” even the most problematic emissions, allowing for more effective mitigation and greater control,” he adds.



Hoedemakers continues, “That means in the event of a chemical escape, not only can we quickly differentiate between technical emissions and potentially dangerous gas leaks, but we can put the right measures in place at the right time to ensure that our staff and local communities are safe.”

The employees and neighboring communities are also pleased, due to the fact that the new monitoring system has significantly reduced the risk of toxic ammonia emissions.

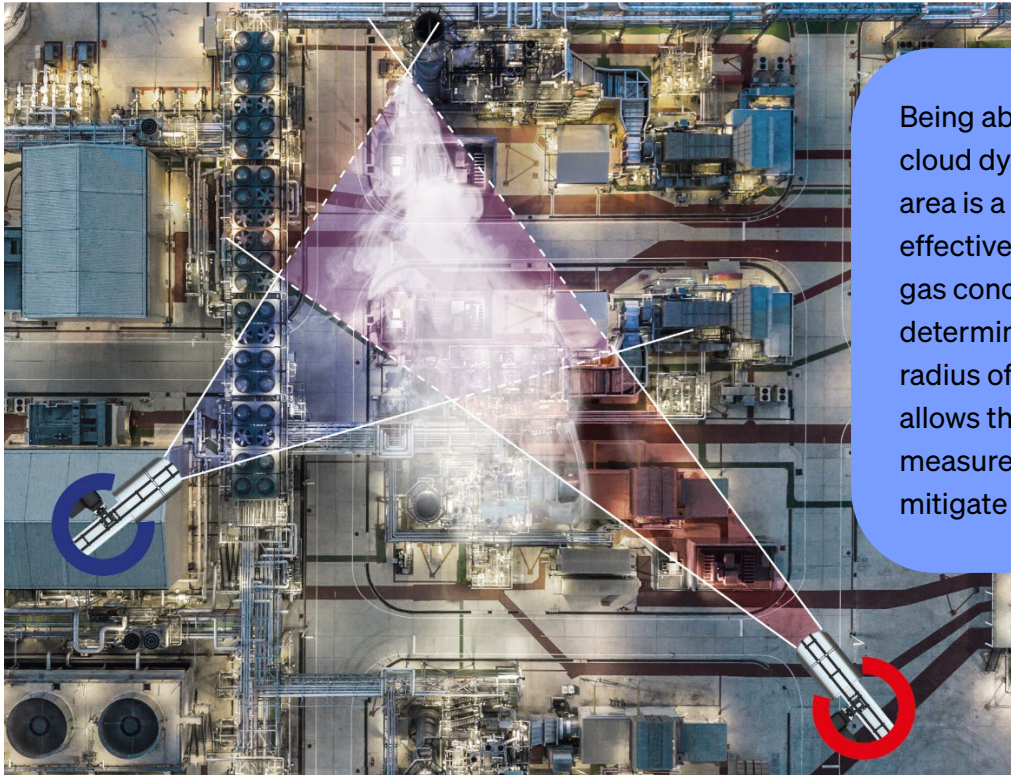

Being able to map the gas cloud dynamics across a wide area is a key factor for effectiveness, as it allows the gas concentrations to be determined across a wide radius of the incident. This allows the appropriate measures to be put in place to mitigate the effects of the leak.

With the help of two or more sensor units, gas cloud positions can be located in 3D by triangulation and concentration distributions can be determined by tomographic reconstruction.

Conclusion

The challenges and limitations of conventional monitoring systems highlight the need for advanced technologies. Remote monitoring systems that work with FTIR spectroscopy not only allow autonomous continuous monitoring but also show real-time gas cloud mapping with intuitive software. It is precisely this detailed yet easy-to-understand presentation of data that enables users to monitor large and complex areas securely around the clock.